





The Fukushima Daiichi Incident

1. Plant Design
2. Accident Progression
3. Radiological releases
4. Spent fuel pools
5. Sources of Information

Matthias Braun
PEPA4-G, AREVA–NP GmbH
Matthias.Braun@AREVA.com

The Fukushima Daiichi Incident

1. Plant Design



► Fukushima Daiichi (Plant I)

- ◆ Unit I - GE Mark I BWR (439 MW), Operating since 1971
- ◆ Unit II-IV - GE Mark I BWR (760 MW), Operating since 1974

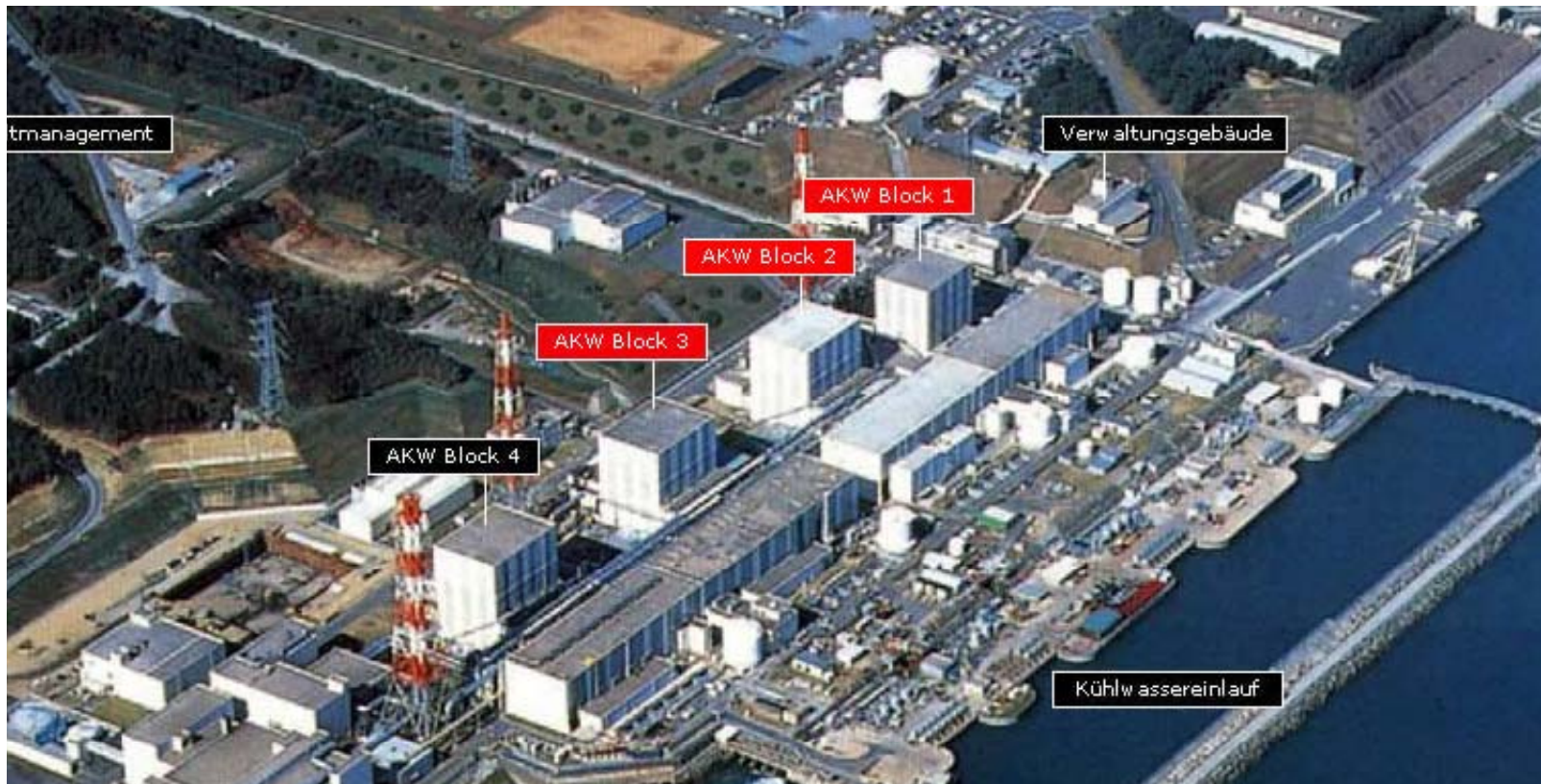

The Fukushima Daiichi Incident

1. Plant Design

► Building structure

- ◆ Concrete Building
- ◆ Steel-framed Service Floor

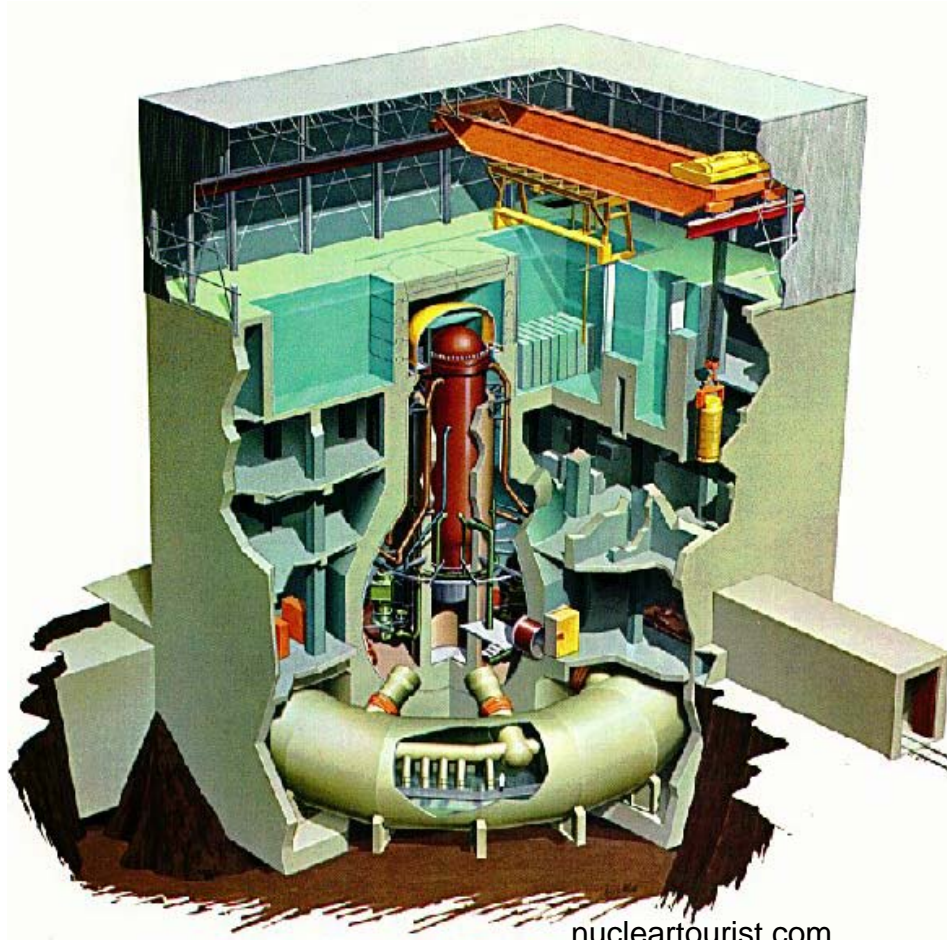

► Containment

- ◆ Pear-shaped Dry-Well
- ◆ Torus-shaped Wet-Well

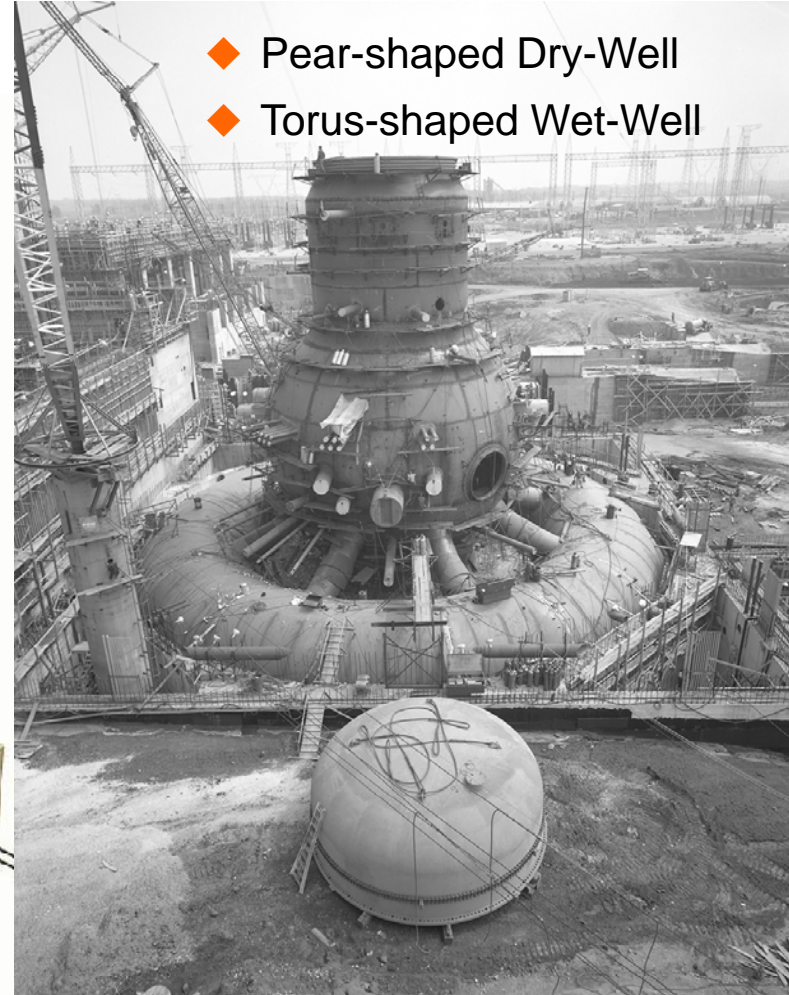

The Fukushima Daiichi Incident

1. Plant Design



► Service Floor



The Fukushima Daiichi Incident

1. Plant Design



- ▶ Lifting the Containment closure head



The Fukushima Daiichi Incident

1. Plant Design

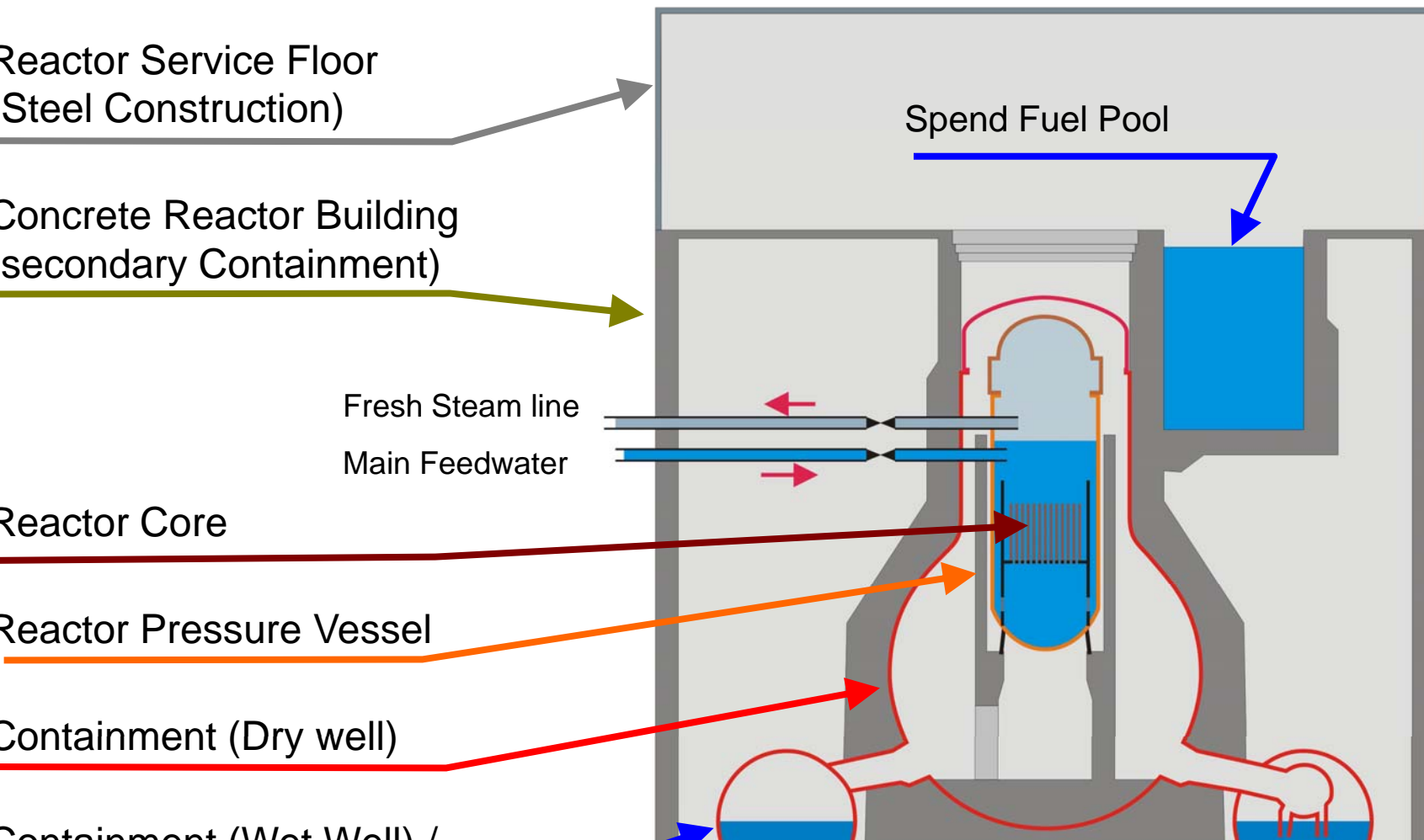

The Fukushima Daiichi Incident

2. Accident progression



11.3.2011 14:46 - Earthquake

- ◆ Magnitude 9
- ◆ Power grid in northern Japan fails
- ◆ Reactors itself are mainly undamaged

SCRAM

- ◆ Power generation due to Fission of Uranium stops
- ◆ Heat generation due to radioactive Decay of Fission Products
 - After Scram ~6%
 - After 1 Day ~1%
 - After 5 Days ~0.5%

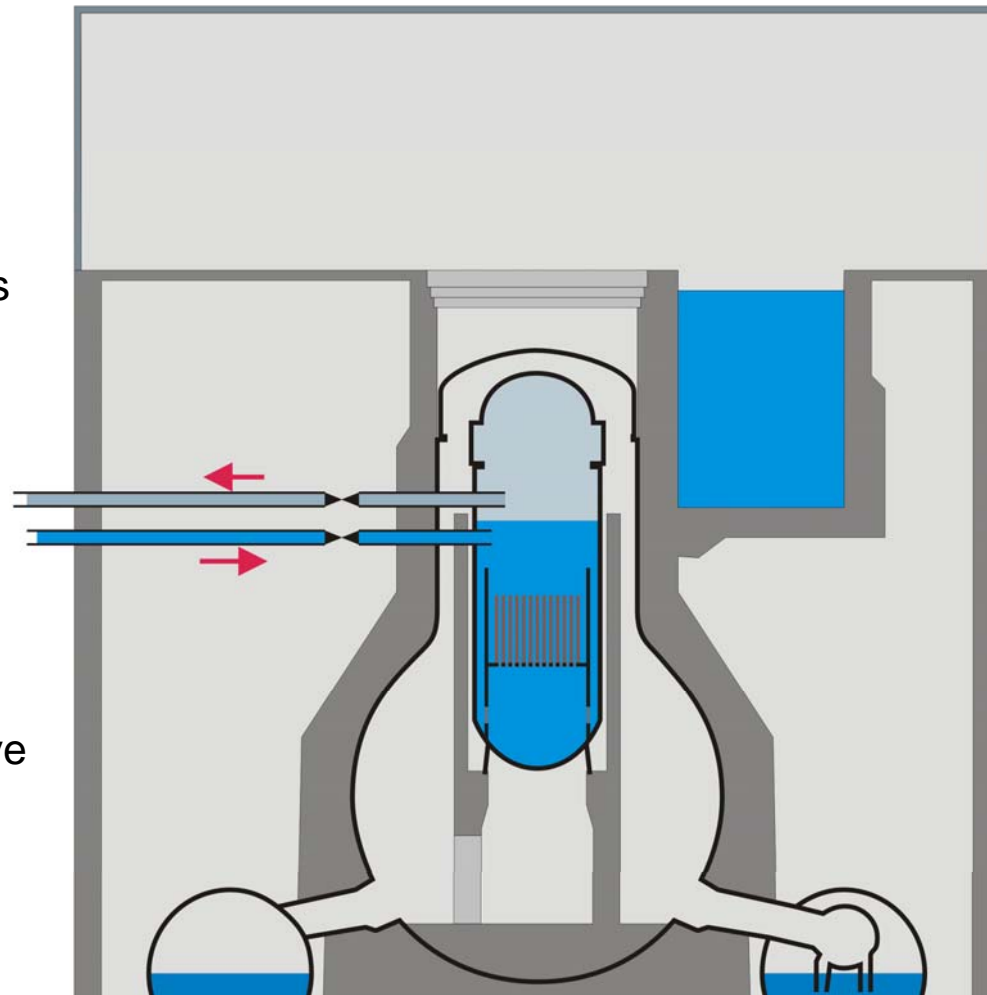

The Fukushima Daiichi Incident

2. Accident progression



Containment Isolation

- ◆ Closing of all non-safety related Penetrations of the containment
- ◆ Cuts off Machine hall
- ◆ If containment isolation succeeds, a large early release of fission products is highly unlikely

Diesel generators start

- ◆ Emergency Core cooling systems are supplied

Plant is in a stable save state

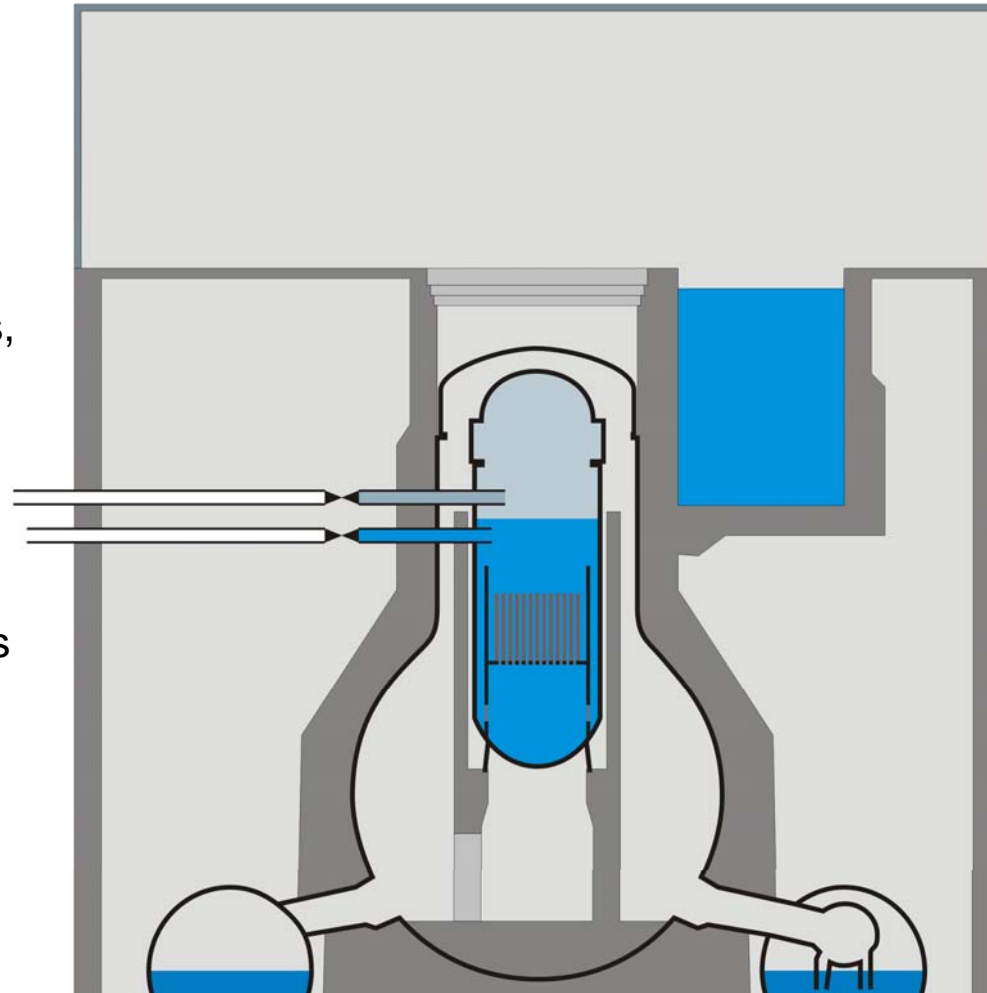

The Fukushima Daiichi Incident

2. Accident progression



11.3. 15:41 Tsunami hits the plant

- ◆ Plant Design for Tsunami height of up to 6.5m
- ◆ Actual Tsunami height >7m
- ◆ Flooding of
 - Diesel Generators and/or
 - Essential service water building cooling the generators

Station Blackout

- ◆ Common cause failure of the power supply
- ◆ Only Batteries are still available
- ◆ Failure of all but one Emergency core cooling systems

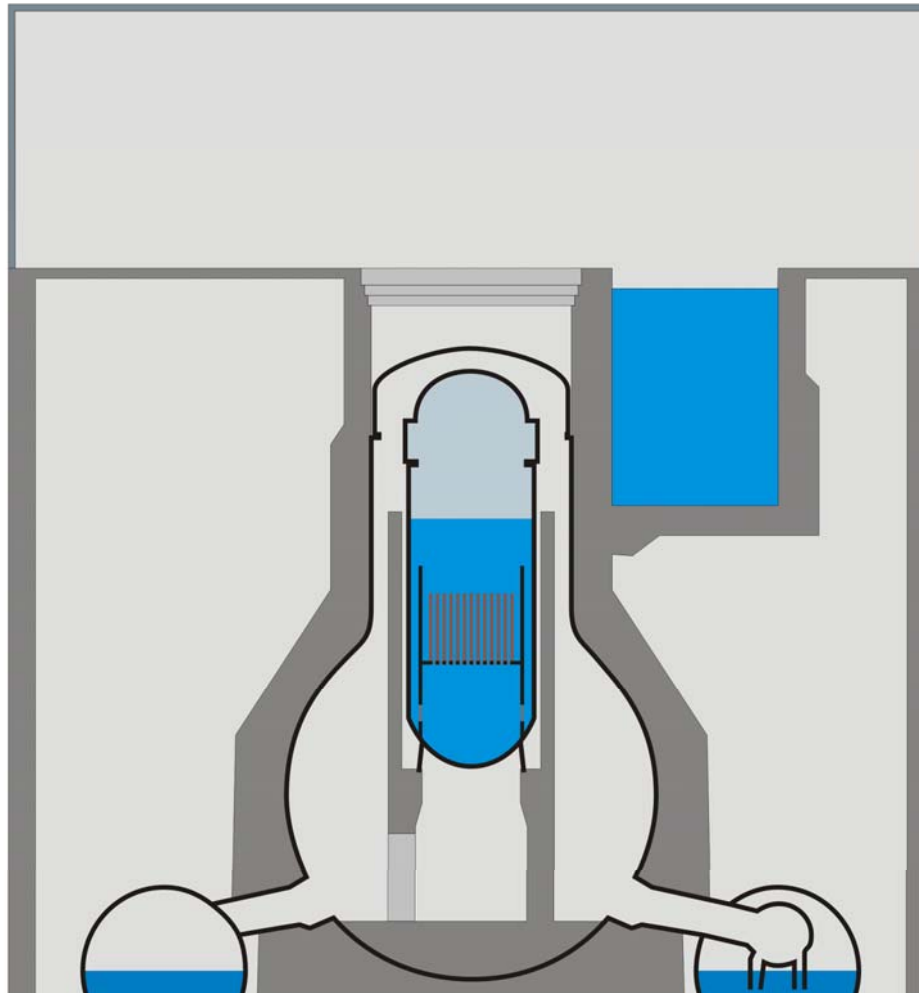

The Fukushima Daiichi Incident

2. Accident progression



Reactor Core Isolation Pump still available

- ◆ Steam from the Reactor drives a Turbine
- ◆ Steam gets condensed in the Wet-Well
- ◆ Turbine drives a Pump
- ◆ Water from the Wet-Well gets pumped in Reactor
- ◆ Necessary:
 - Battery power
 - Temperature in the wet-well must be below 100°C

As there is no heat removal from the building, the Core isolation pump can't work infinitely

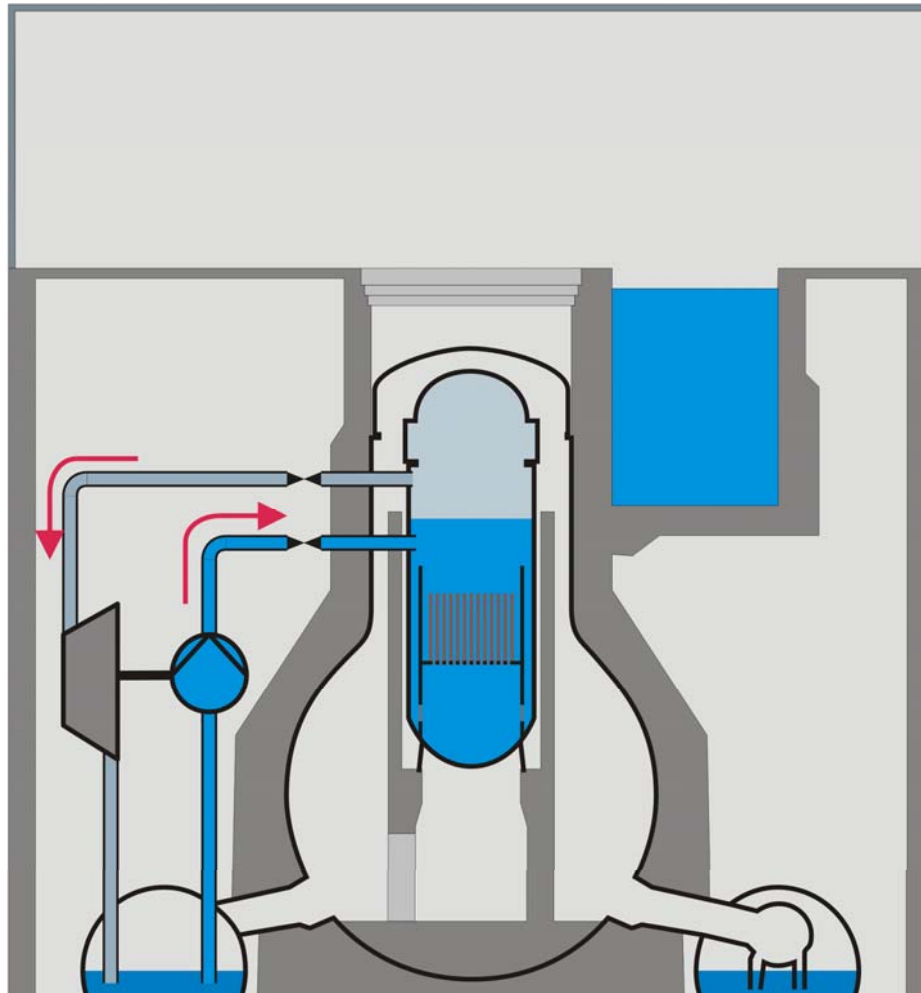

The Fukushima Daiichi Incident

2. Accident progression



Reactor Isolation pump stops

- ◆ 11.3. 16:36 in Unit 1
(Batteries empty)
- ◆ 14.3. 13:25 in Unit 2
(Pump failure)
- ◆ 13.3. 2:44 in Unit 3
(Batteries empty)

Decay Heat produces still steam in
Reactor pressure Vessel

- ◆ Pressure rising

Opening the steam relieve valves

- ◆ Discharge Steam into the Wet-Well

Descending of the Liquid Level in

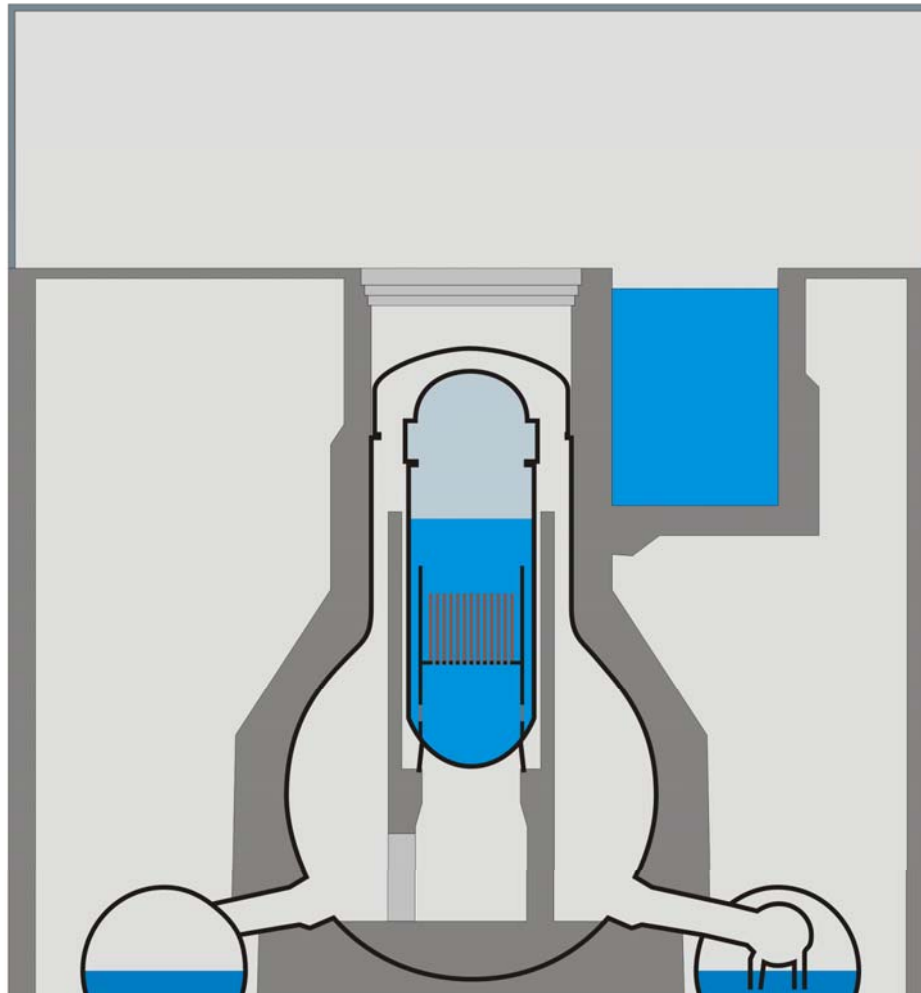

The Fukushima Daiichi Incident

2. Accident progression



Reactor Isolation pump stops

- ◆ 11.3. 16:36 in Unit 1
(Batteries empty)
- ◆ 14.3. 13:25 in Unit 2
(Pump failure)
- ◆ 13.3. 2:44 in Unit 3
(Batteries empty)

Decay Heat produces still steam in
Reactor pressure Vessel

- ◆ Pressure rising

Opening the steam relieve valves

- ◆ Discharge Steam into the Wet-Well

Descending of the Liquid Level in

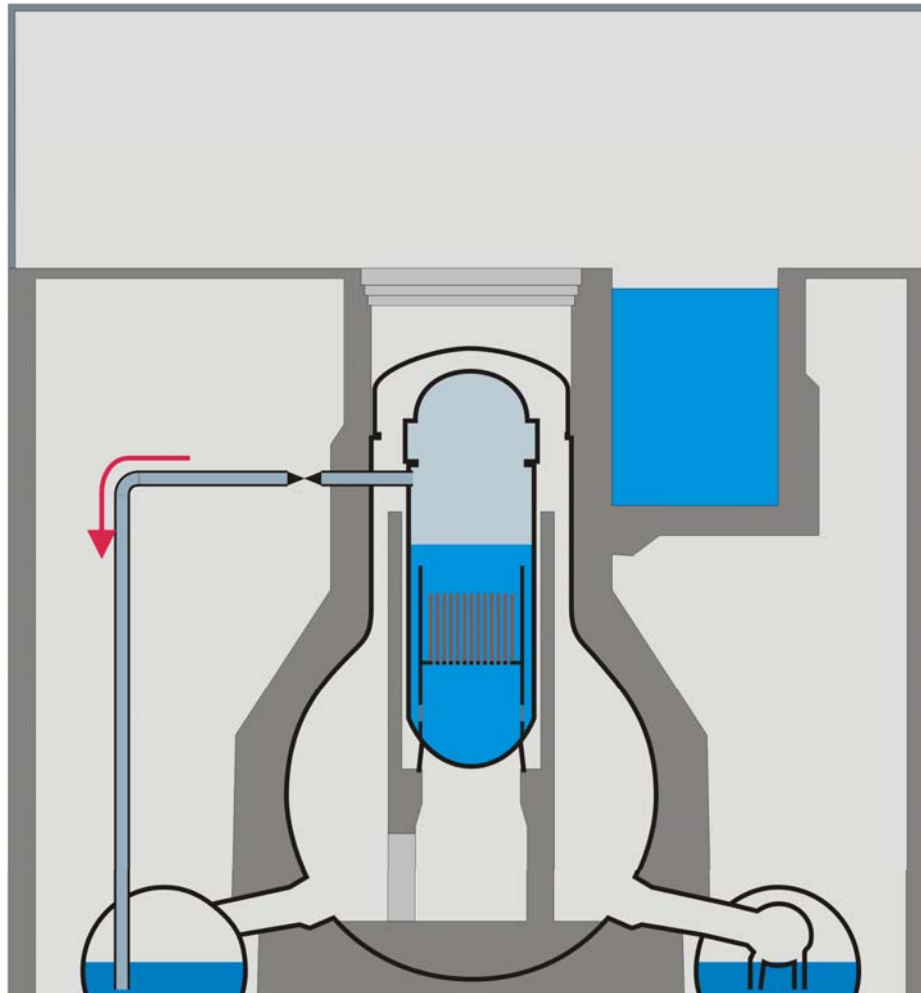

The Fukushima Daiichi Incident

2. Accident progression



Reactor Isolation pump stops

- ◆ 11.3. 16:36 in Unit 1
(Batteries empty)
- ◆ 14.3. 13:25 in Unit 2
(Pump failure)
- ◆ 13.3. 2:44 in Unit 3
(Batteries empty)

Decay Heat produces still steam in
Reactor pressure Vessel

- ◆ Pressure rising

Opening the steam relieve valves

- ◆ Discharge Steam into the Wet-Well

Descending of the Liquid Level in

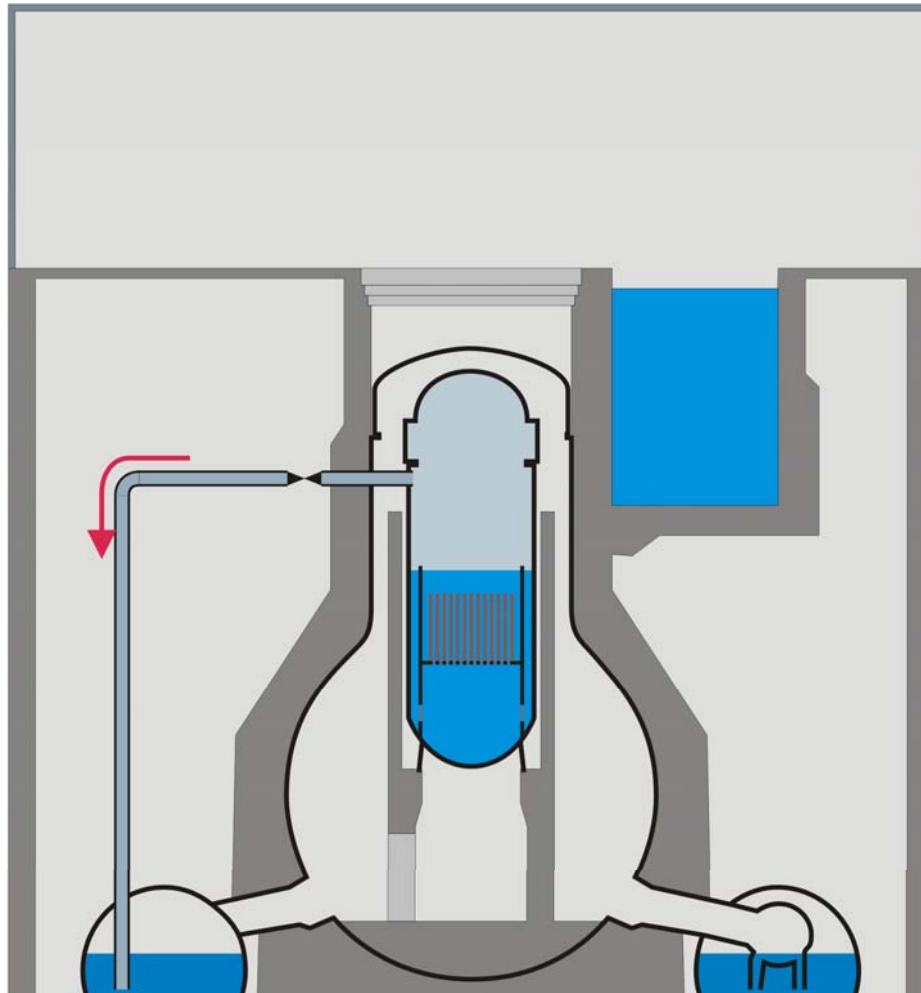

The Fukushima Daiichi Incident

2. Accident progression



Reactor Isolation pump stops

- ◆ 11.3. 16:36 in Unit 1
(Batteries empty)
- ◆ 14.3. 13:25 in Unit 2
(Pump failure)
- ◆ 13.3. 2:44 in Unit 3
(Batteries empty)

Decay Heat produces still steam in
Reactor pressure Vessel

- ◆ Pressure rising

Opening the steam relieve valves

- ◆ Discharge Steam into the Wet-Well

Descending of the Liquid Level in

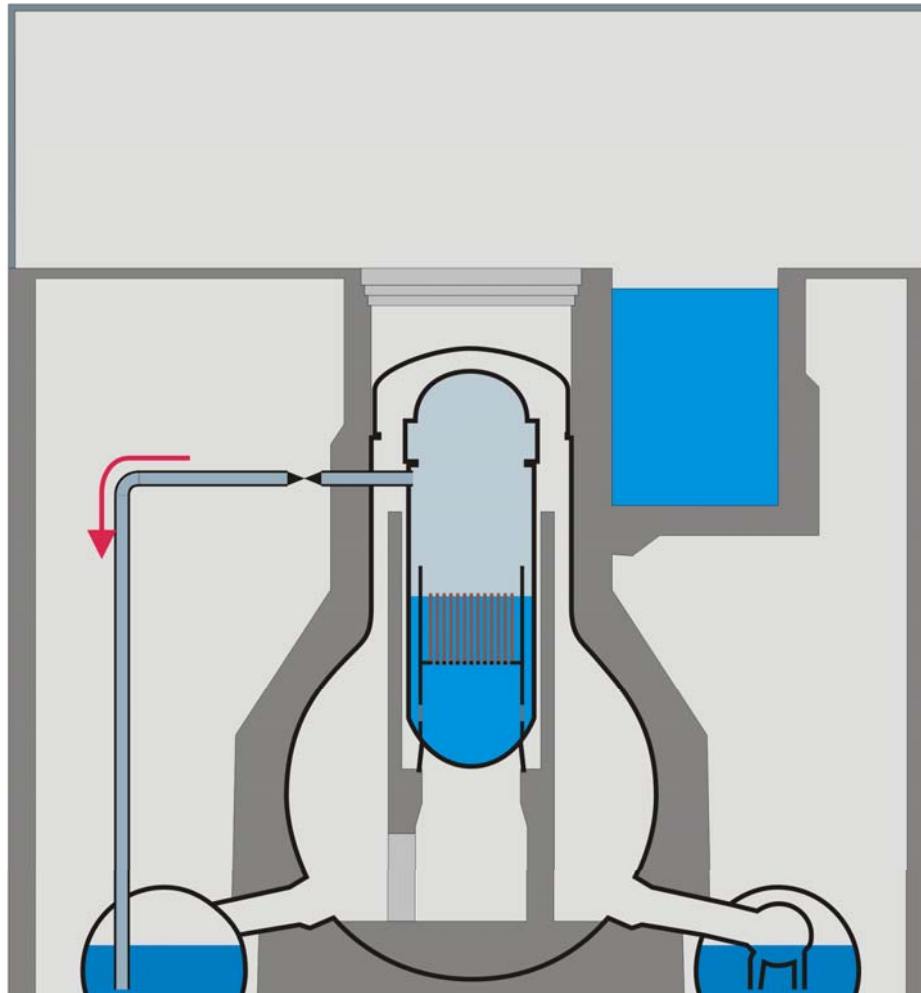

The Fukushima Daiichi Incident

2. Accident progression



Reactor Isolation pump stops

- ◆ 11.3. 16:36 in Unit 1
(Batteries empty)
- ◆ 14.3. 13:25 in Unit 2
(Pump failure)
- ◆ 13.3. 2:44 in Unit 3
(Batteries empty)

Decay Heat produces still steam in
Reactor pressure Vessel

- ◆ Pressure rising

Opening the steam relieve valves

- ◆ Discharge Steam into the Wet-Well

Descending of the Liquid Level in

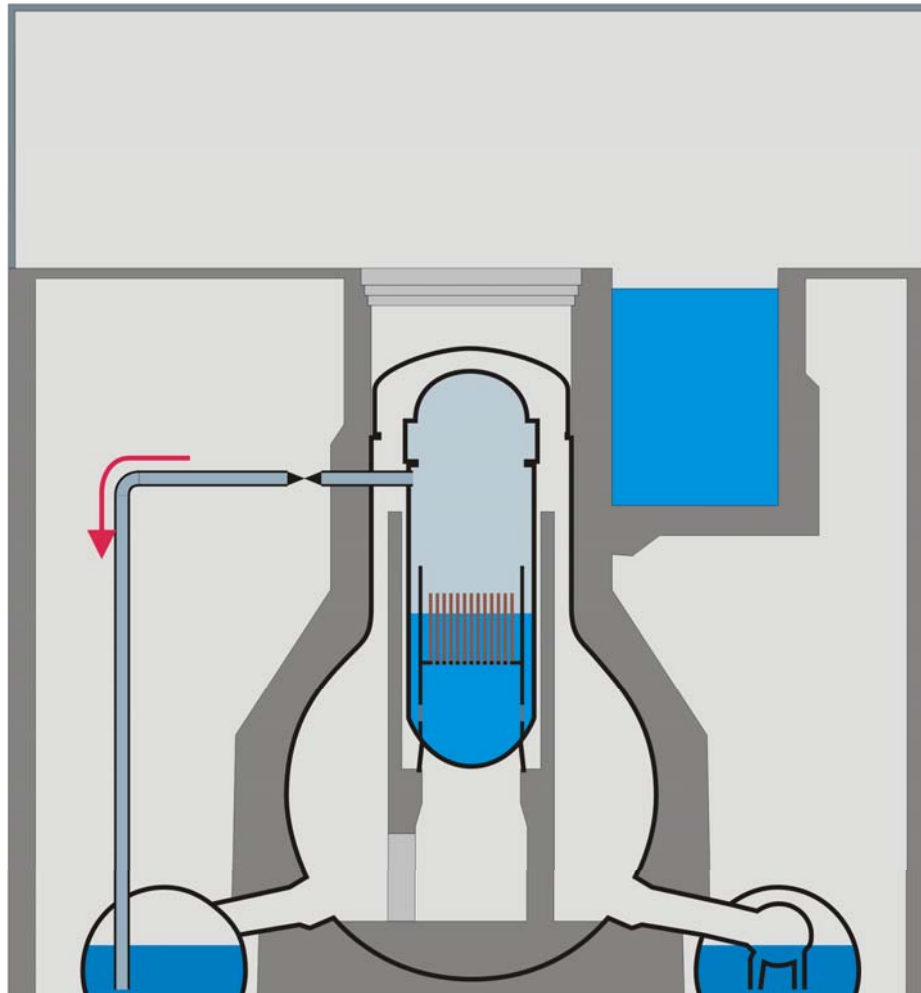

The Fukushima Daiichi Incident

2. Accident progression



Measured, and here referenced
Liquid level is the collapsed level.
The actual liquid level lies higher
due to the steam bubbles in the
liquid

-50% of the core exposed

- ◆ Cladding temperatures rise, but still no significant core damage

-2/3 of the core exposed

- ◆ Cladding temperature exceeds $\sim 900^{\circ}\text{C}$
- ◆ Ballooning / Breaking of the cladding

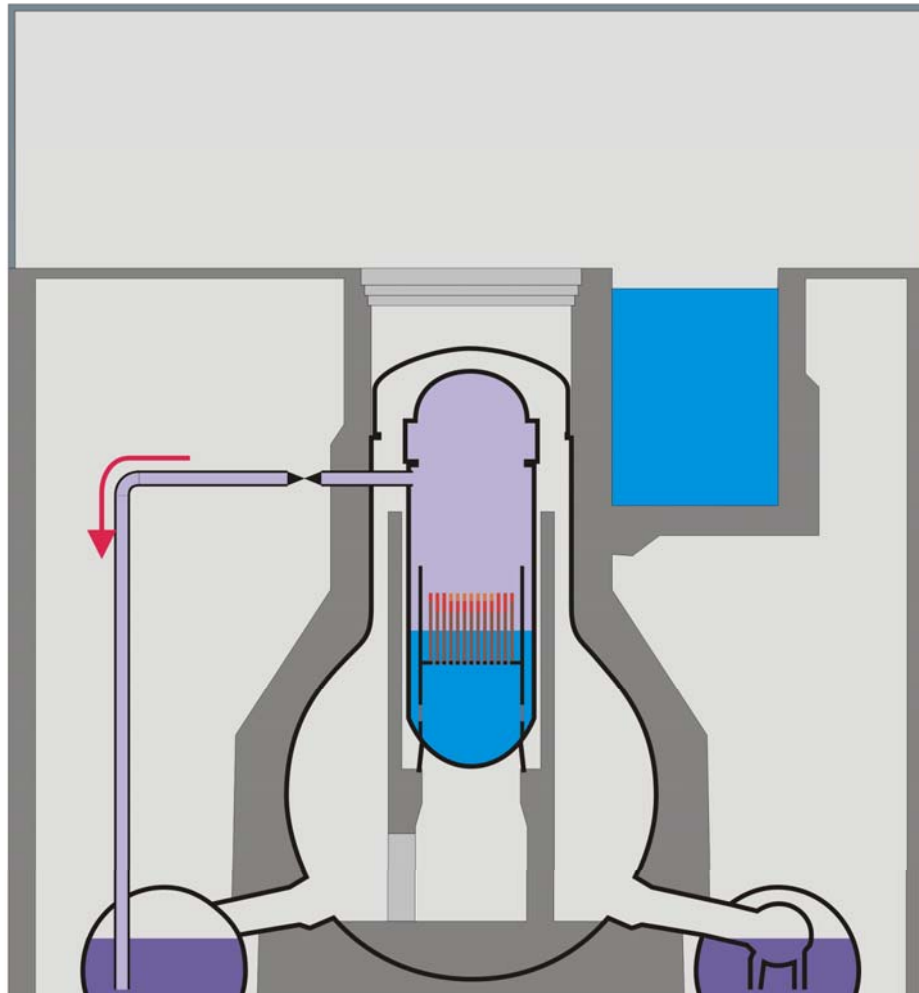

The Fukushima Daiichi Incident

2. Accident progression



-3/4 of the core exposed

- ◆ Cladding exceeds $\sim 1200^{\circ}\text{C}$
- ◆ Zirconium in the cladding starts to burn under Steam atmosphere
- ◆ $\text{Zr} + 2\text{H}_2\text{O} \rightarrow \text{ZrO}_2 + 2\text{H}_2$
- ◆ Exothermal reaction further heats the core
- ◆ Generation of hydrogen
 - Unit 1: 300-600kg
 - Unit 2/3: 300-1000kg
- ◆ Hydrogen gets pushed via the wet-well, the wet-well vacuum breakers into the dry-well

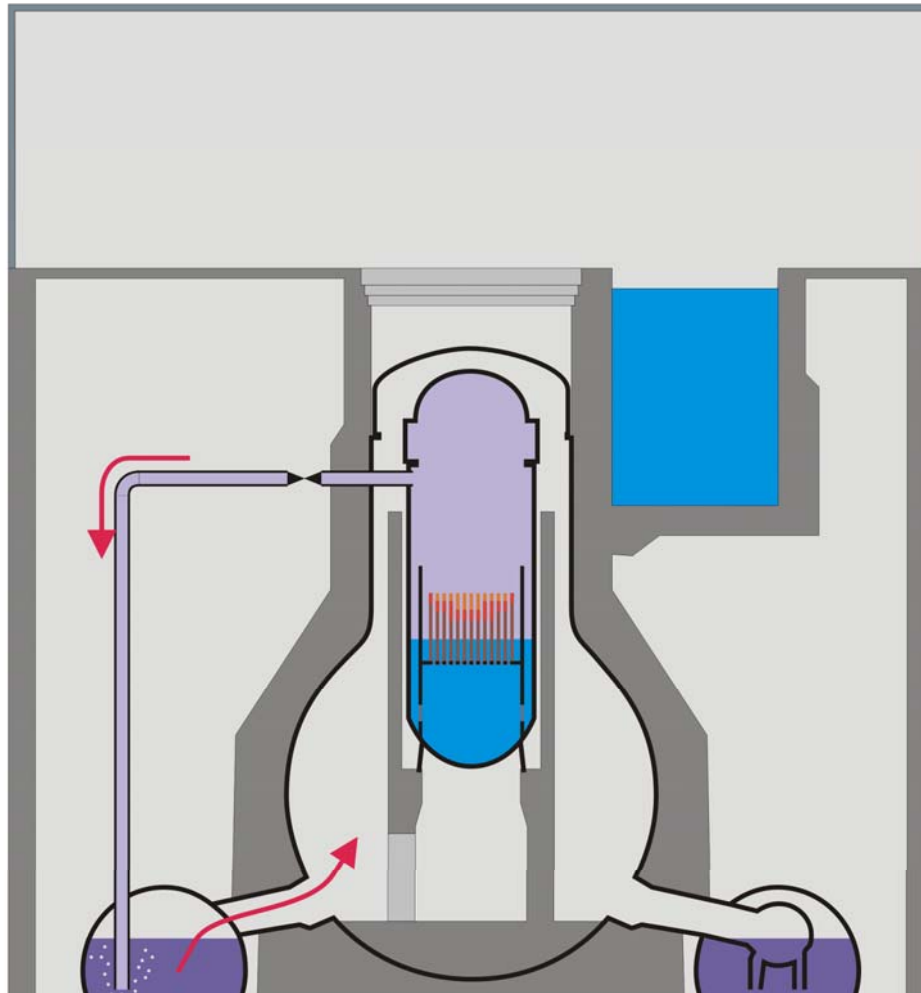

The Fukushima Daiichi Incident

2. Accident progression



t ~1800°C [Unit 1,2,3]

- ◆ Melting of the Cladding
- ◆ Melting of the steel structures

t ~2500°C [Block 1,2]

- ◆ Breaking of the fuel rods
- ◆ debris bed inside the core

t ~2700°C [Block 1]

- ◆ Melting of Uranium-Zirconium eutectics

Restoration of the water supply
stops accident in all 3 Units

- ◆ Unit 1: 12.3. 20:20 (27h w.o. water)
- ◆ Unit 2: 14.3. 20:33 (7h w.o. water)

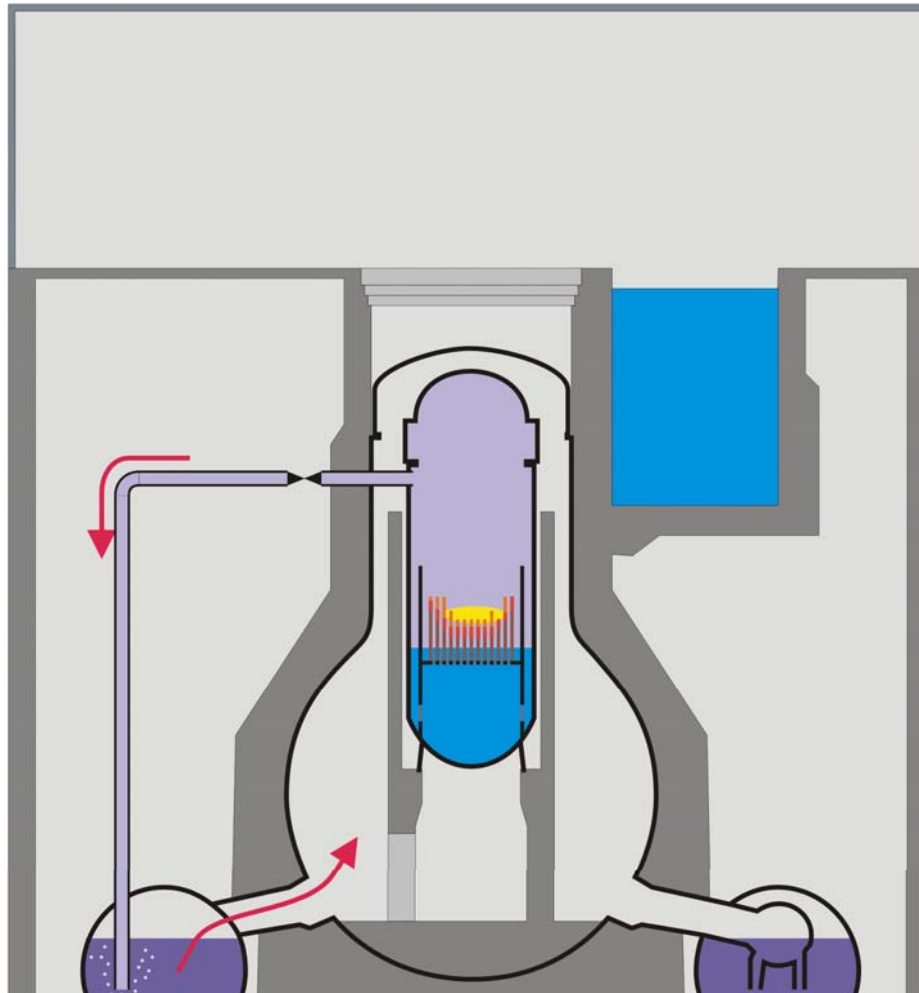

The Fukushima Daiichi Incident

2. Accident progression



Release of fission products during
melt down

- ◆ Xenon, Cesium, Iodine,...
- ◆ Uranium/Plutonium remain in core
- ◆ Fission products condensate to airborne Aerosols

Discharge through valves into water
of the condensation chamber

- ◆ Pool scrubbing binds a fraction of
Aerosols in the water

Xenon and remaining aerosols
enter the Dry-Well

- ◆ Deposition of aerosols on surfaces

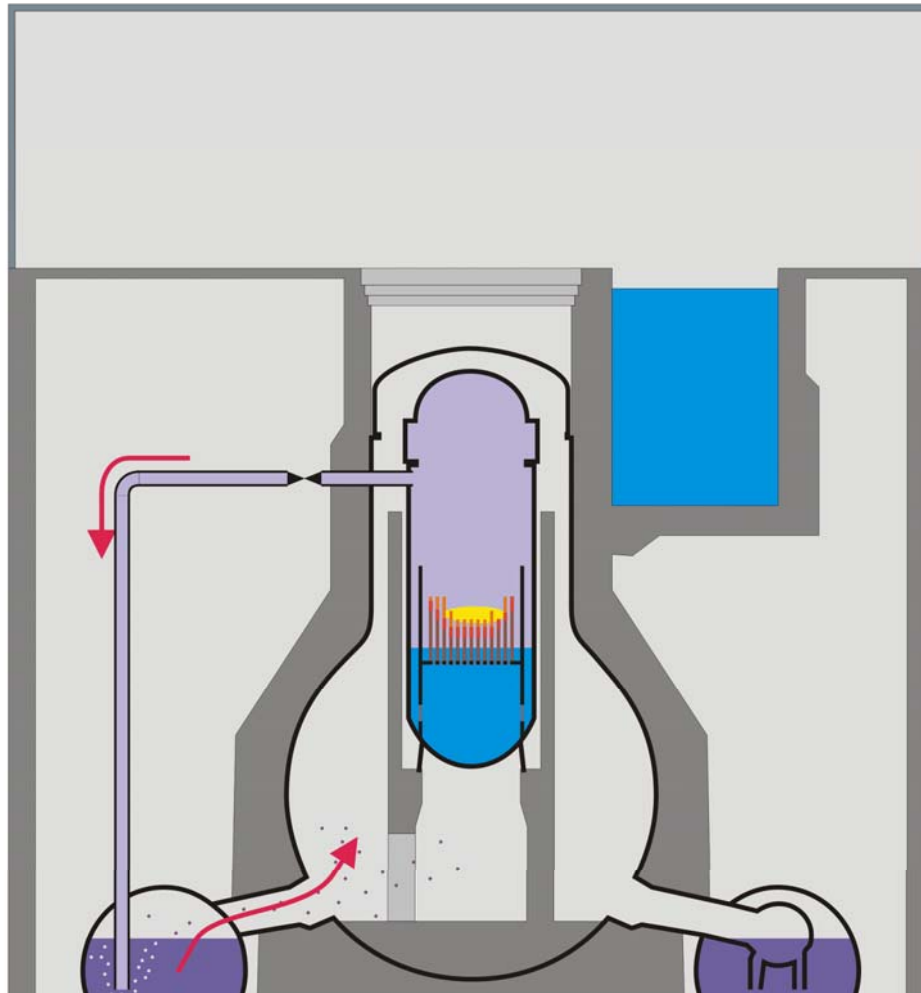

The Fukushima Daiichi Incident

2. Accident progression



Containment

- ◆ Last barrier between Fission Products and Environment
- ◆ Wall thickness ~3cm
- ◆ Design Pressure 4-5bar

Actual pressure up to 8 bars

- ◆ Normal inert gas filling (Nitrogen)
- ◆ Hydrogen from core oxidation
- ◆ Boiling condensation chamber (like a pressure cooker)

Depressurization of the containment

- ◆ Unit 1: 12.3. 4:00
- ◆ Unit 2: 13.3 00:00

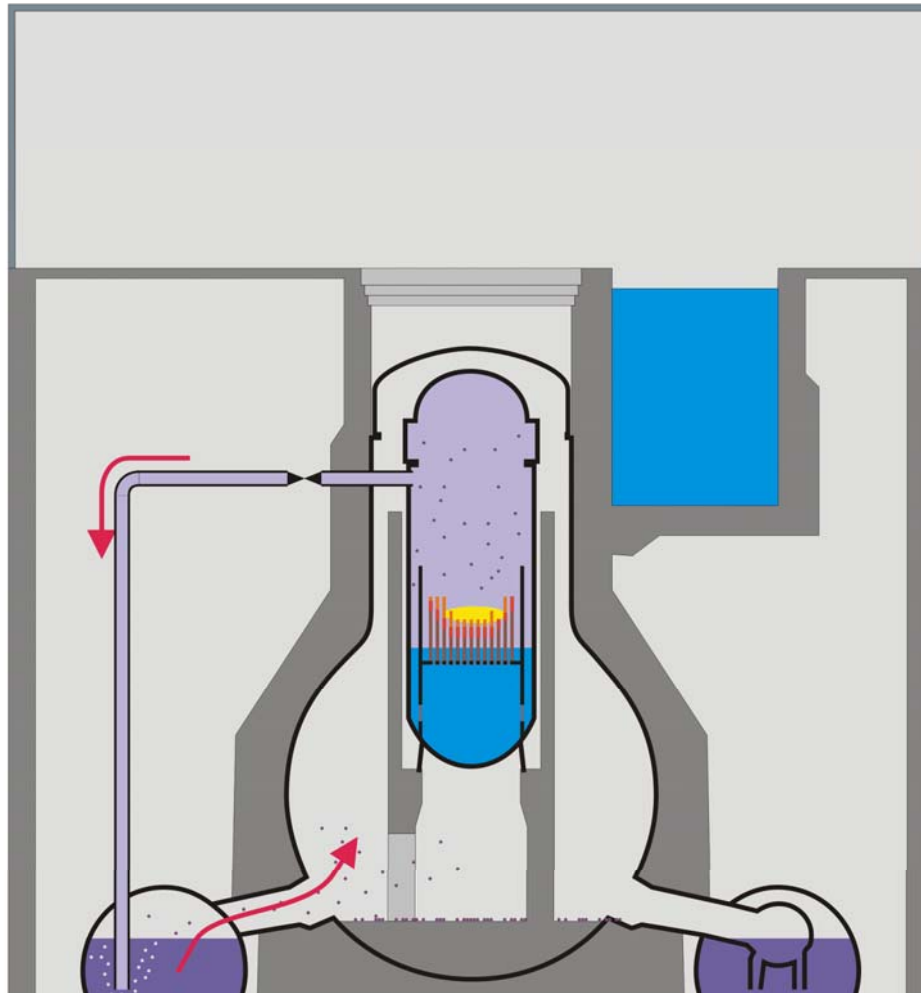

The Fukushima Daiichi Incident

2. Accident progression



Positive and negative Aspects of depressurizing the containment

- ◆ Removes Energy from the Reactor building (only way left)
- ◆ Reducing the pressure to ~4 bar
- ◆ Release of small amounts of Aerosols (Iodine, Cesium ~0.1%)
- ◆ Release of all noble gases
- ◆ Release of Hydrogen

Gas is released into the reactor service floor

- ◆ Hydrogen is flammable

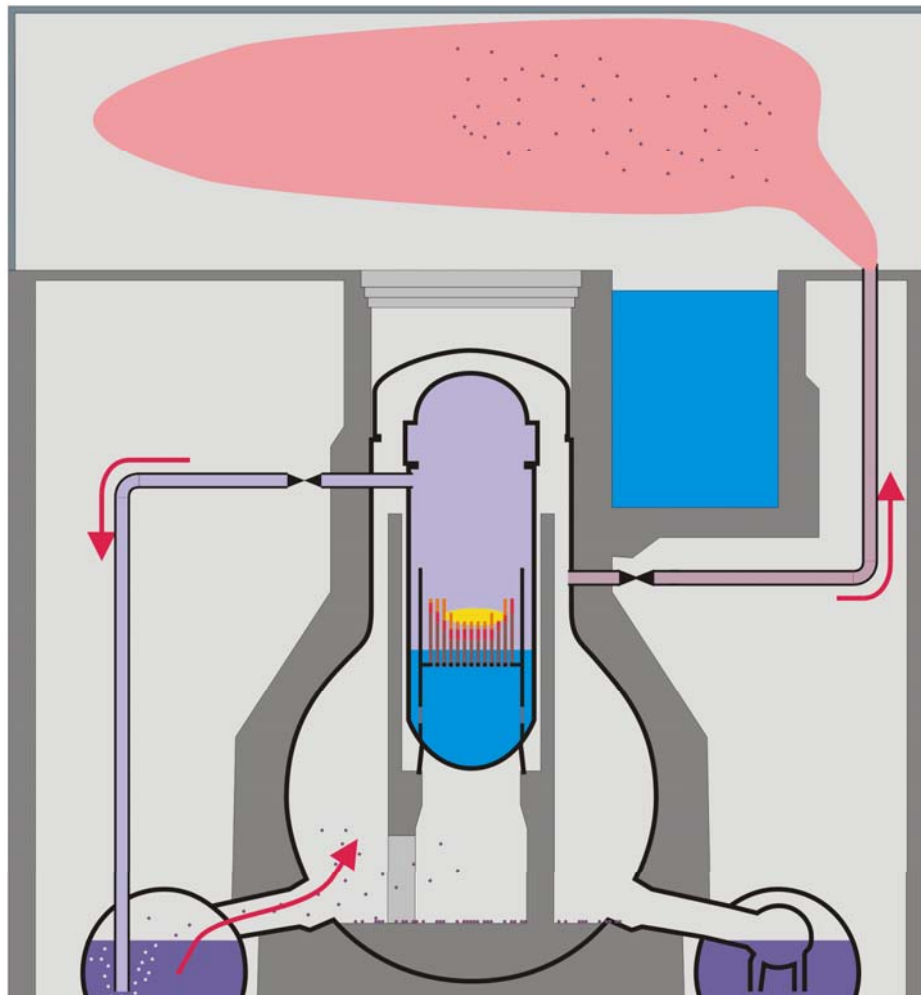

The Fukushima Daiichi Incident

2. Accident progression

Unit 1 und 3

- ◆ Hydrogen burn inside the reactor service floor
- ◆ Destruction of the steel-frame roof
- ◆ Reinforced concrete reactor building seems undamaged
- ◆ Spectacular but minor safety relevant

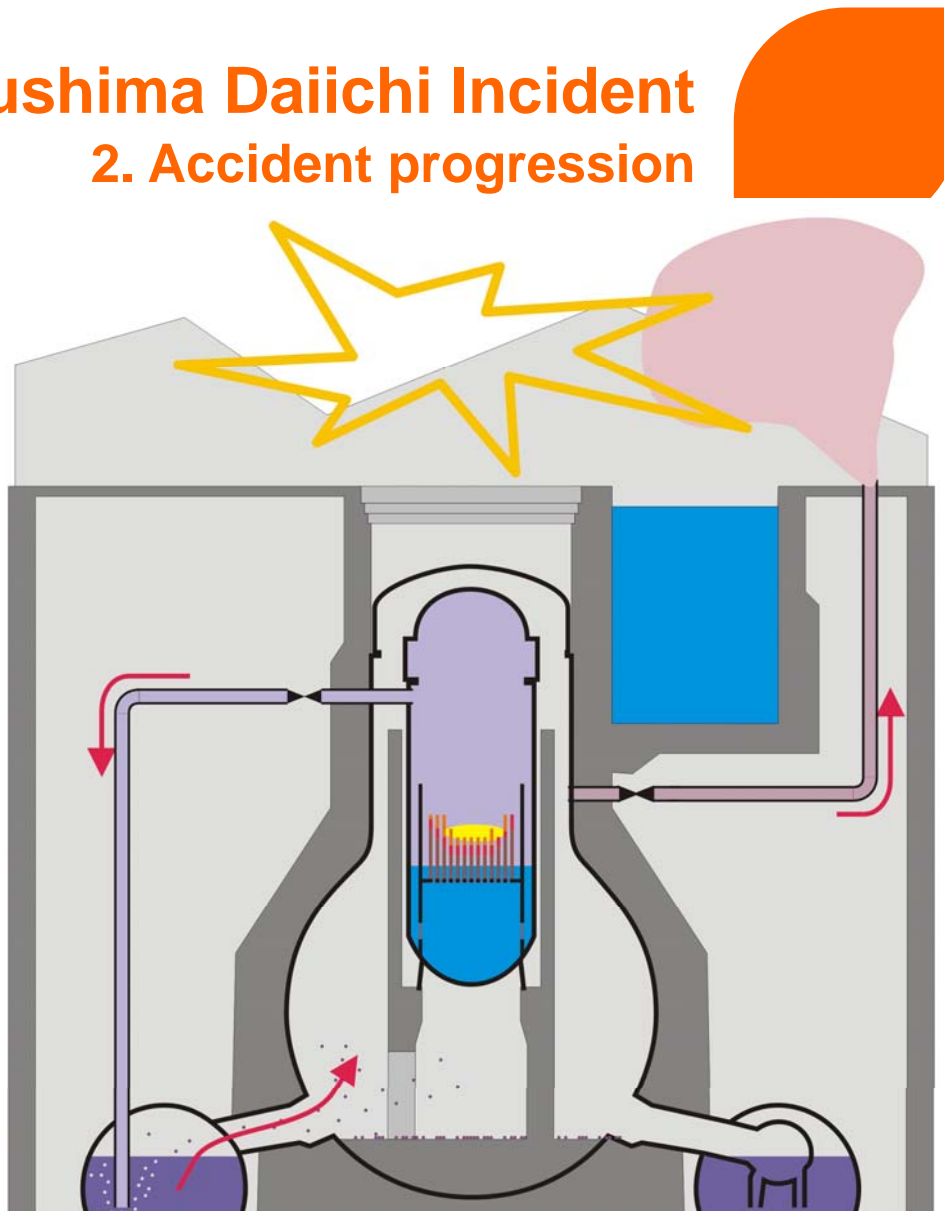

The Fukushima Daiichi Incident

2. Accident progression



Unit 2

- ◆ Hydrogen burn inside the reactor building
- ◆ Probably damage to the condensation chamber (highly contaminated water)
- ◆ Uncontrolled release of gas from the containment
- ◆ **Release of fission products**
- ◆ Temporal evacuation of the plant
- ◆ High local dose rates on the plant site due to wreckage hinder further recovery work

No clear information's why Unit 2 behaved differently

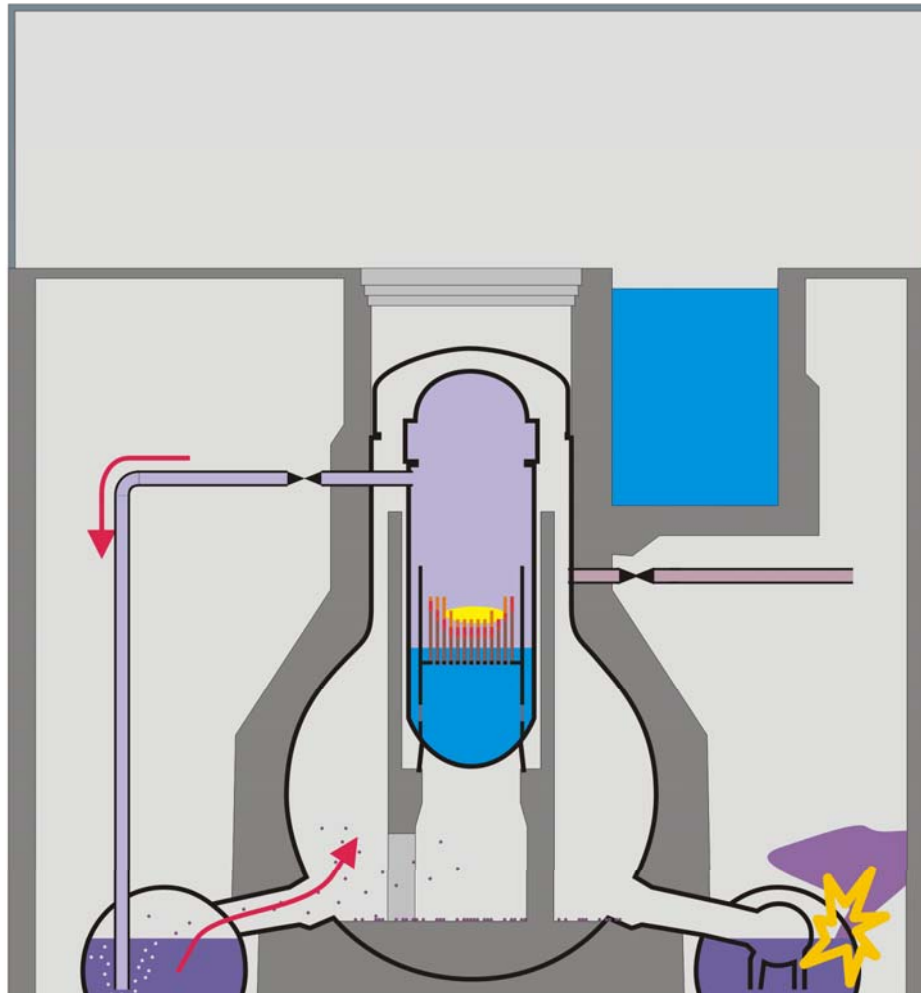

The Fukushima Daiichi Incident

2. Accident progression



Current status of the Reactors

- ◆ Core Damage in Unit 1,2, 3
- ◆ Building damage due to various burns Unit 1-4
- ◆ Reactor pressure vessels flooded in all Units with mobile pumps
- ◆ At least containment in Unit 1 flooded

Further cooling of the Reactors by releasing steam to the atmosphere

Only small further releases of fission products can be expected

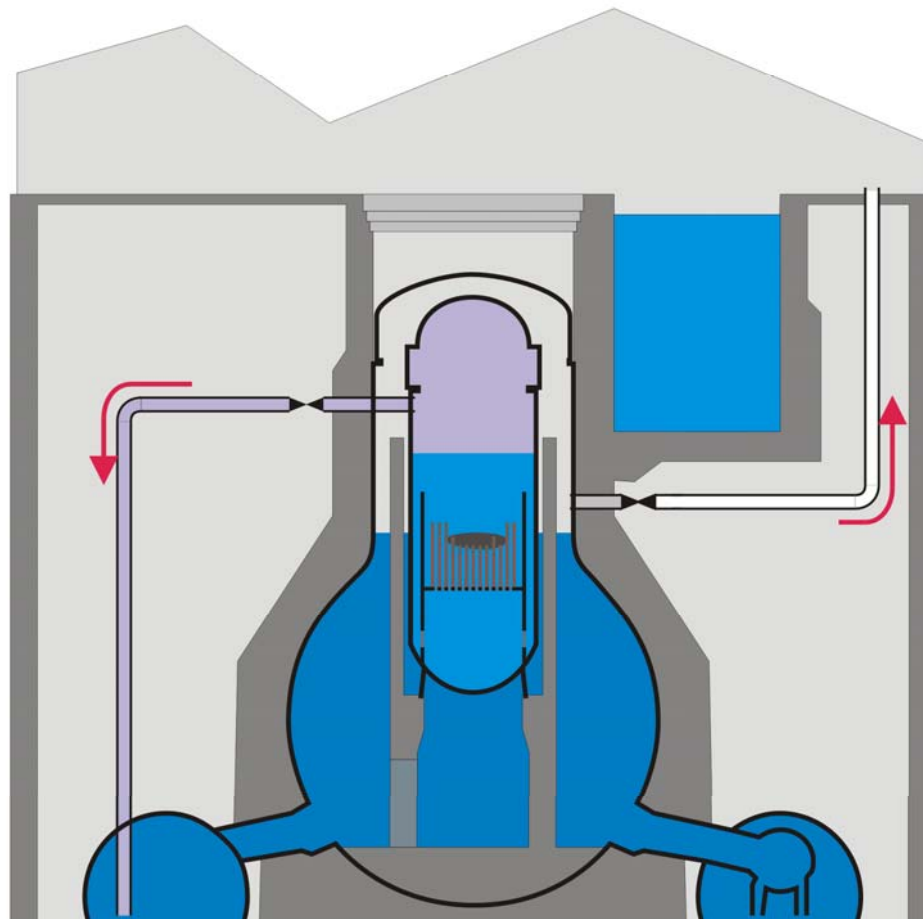

The Fukushima Daiichi Incident

3. Radiological releases



Directly on the plant site

- ◆ Before Explosion in Unit Block 2
 - Below 2mSv / h
 - Mainly due to released radioactive noble gases
 - Measuring posts on west side. Maybe too small values measured due to wind

- ◆ After Explosion in Unit 2 (Damage of the Containment)
 - Temporal peak values 12mSv / h
 - (Origin not entirely clear)
 - Local peak values on site up to 400mSv /h (wreckage / fragments?)
 - Currently stable dose on site at 5mSv /h
 - Inside the buildings a lot more

- ◆ Limiting time of exposure of the workers necessary

The Fukushima Daiichi Incident

3. Radiological releases

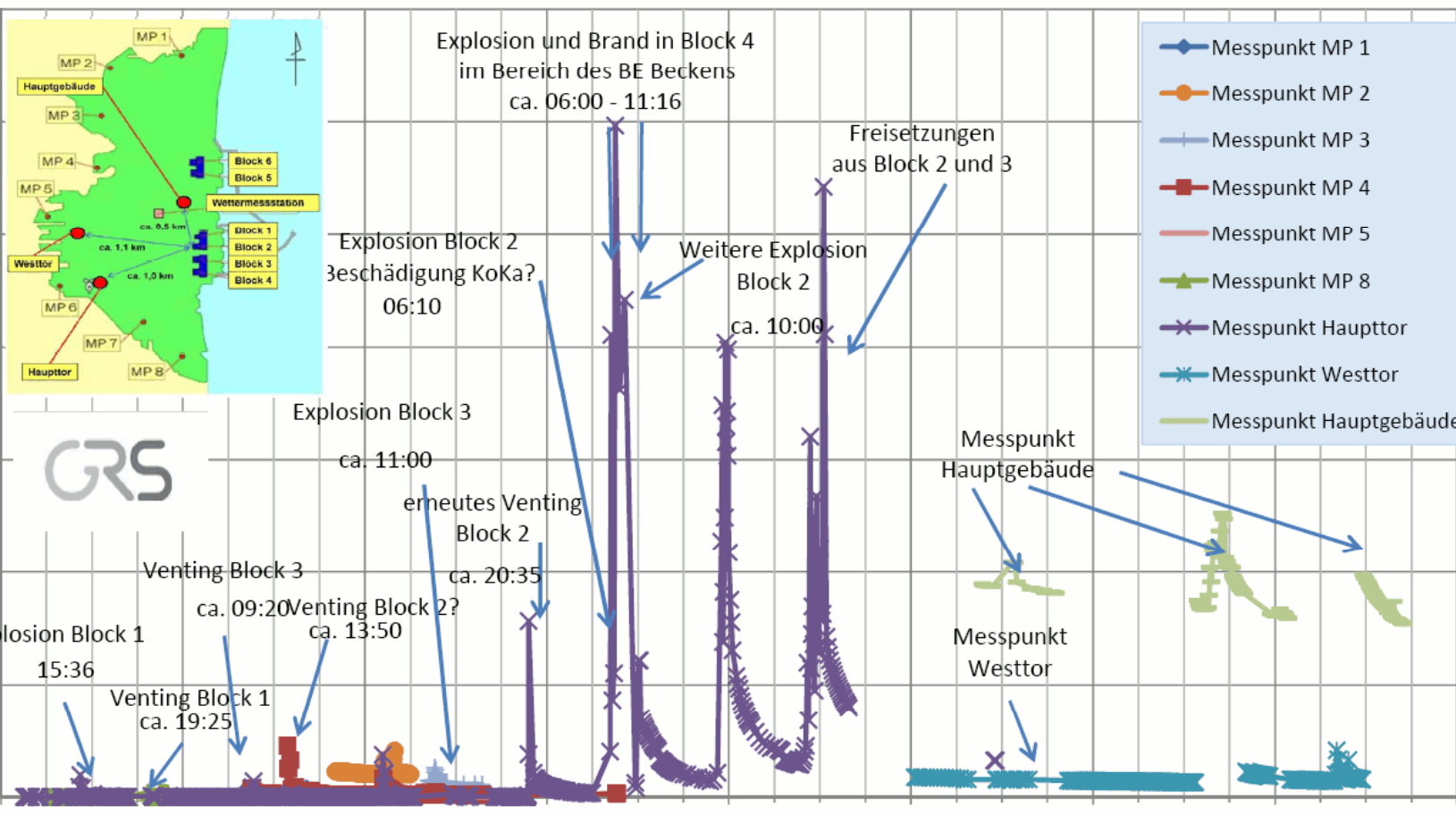
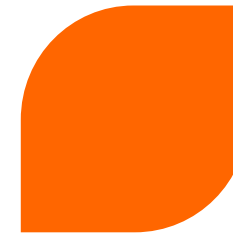

The Fukushima Daiichi Incident

3. Radiological releases



▶ Outside the Plant site

- ◆ As reactor building mostly intact
=> reduced release of Aerosols (not Chernobyl-like)
- ◆ Fission product release in steam
=> fast Aerosol grows, large fraction falls down in the proximity of the plant
- ◆ Main contribution to the radioactive dose outside plant are the radioactive noble gases
- ◆ Carried / distributed by the wind, decreasing dose with time
- ◆ No „Fall-out“ of the noble gases, so no local high contamination of soil

▶ ~20km around the plant

- ◆ Evacuations were adequate
- ◆ Measured dose up to 0.3mSv/h for short times
- ◆ Maybe destruction of crops / dairy products this year
- ◆ Probably no permanent evacuation of land necessary

The Fukushima Daiichi Incident

3. Radiological releases

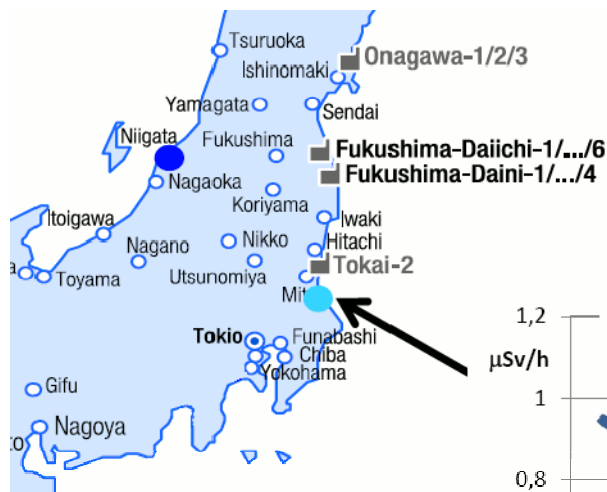

GRS.de

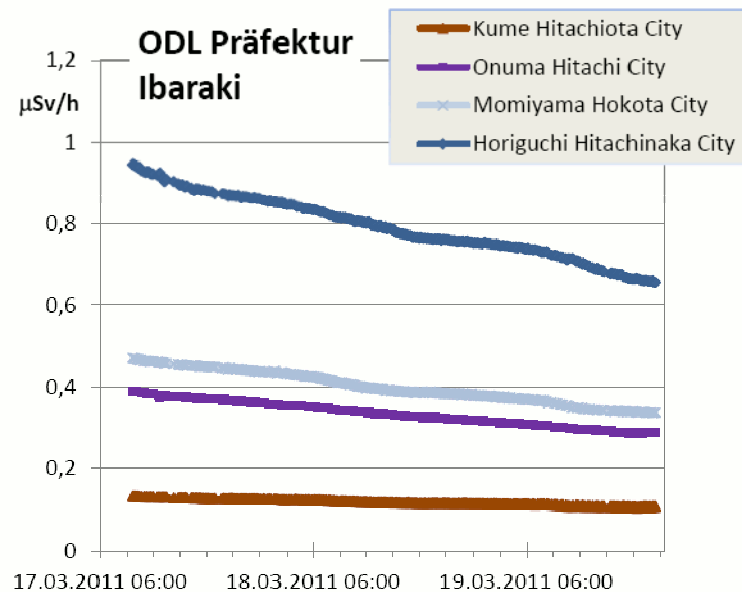

-50km around the plant

- ◆ Control of Crop / Dairy products
- ◆ Usage of Iodine pills
(Caution, pills can interfere with heart medicine)

The Fukushima Daiichi Incident

4. Spent fuel pools



Spent fuel stored in Pool on
Reactor service floor

- ◆ Due to maintenance in Unit 4 entire core stored in Fuel pool
- ◆ Dry-out of the pools
 - Unit 4: in 10 days
 - Unit 1-3,5,6 in few weeks
- ◆ **Leakage of the pools due to Earthquake?**

Consequences

- ◆ Core melt „on fresh air “
- ◆ Nearly no retention of fission products
- ◆ Large release

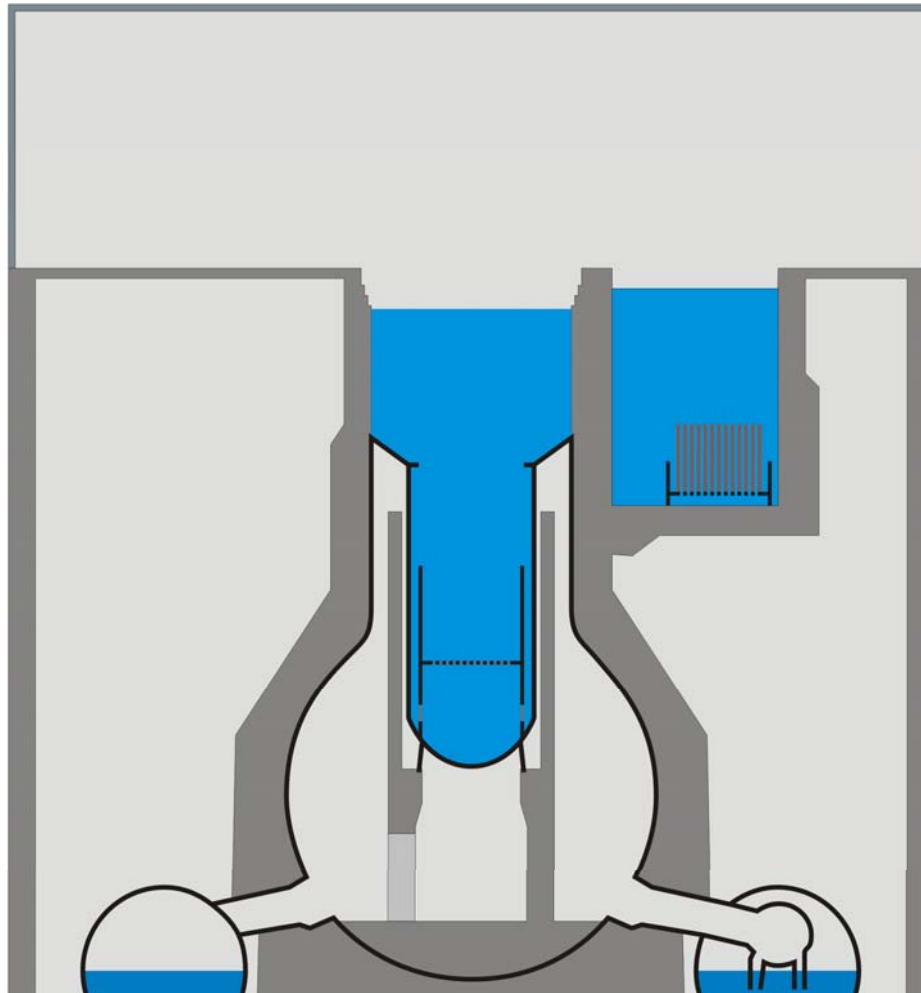

The Fukushima Daiichi Incident

4. Spent fuel pools



Spent fuel stored in Pool on
Reactor service floor

- ◆ Due to maintenance in Unit 4 entire core stored in Fuel pool
- ◆ Dry-out of the pools
 - Unit 4: in 10 days
 - Unit 1-3,5,6 in few weeks
- ◆ **Leakage of the pools due to Earthquake?**

Consequences

- ◆ Core melt „on fresh air “
- ◆ Nearly no retention of fission products
- ◆ Large release

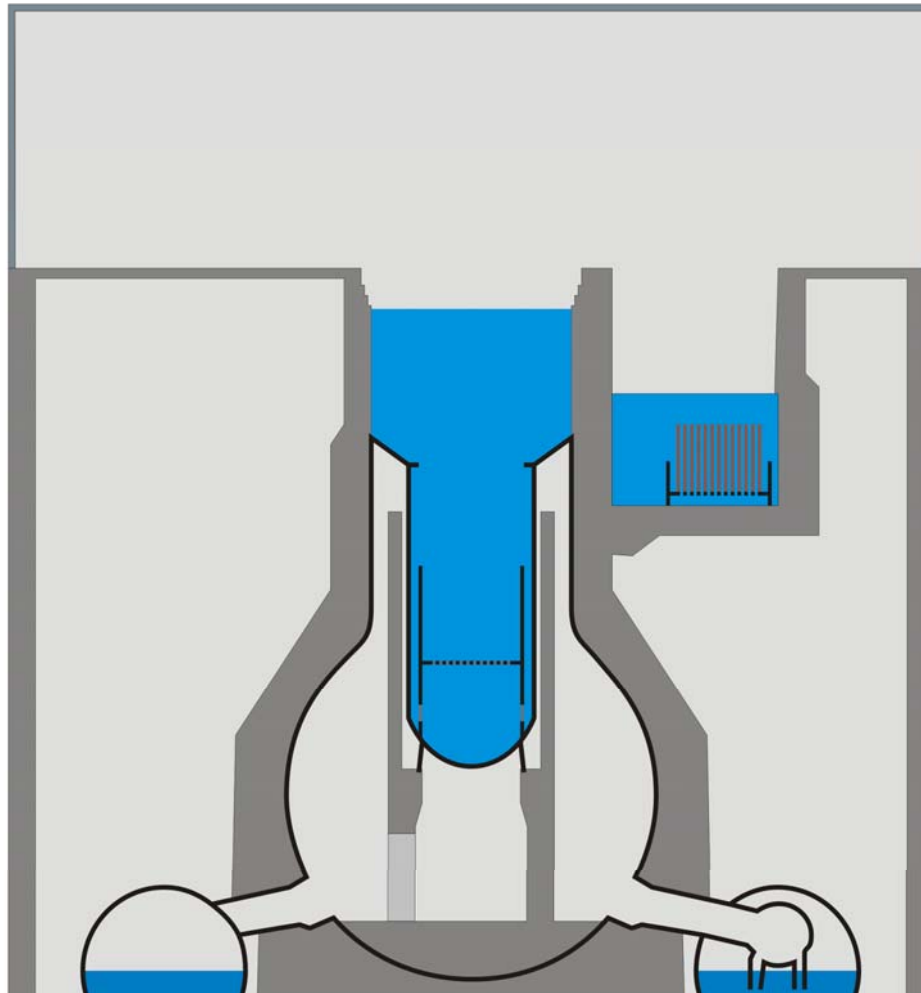

The Fukushima Daiichi Incident

4. Spent fuel pools



Spent fuel stored in Pool on
Reactor service floor

- ◆ Due to maintenance in Unit 4 entire core stored in Fuel pool
- ◆ Dry-out of the pools
 - Unit 4: in 10 days
 - Unit 1-3,5,6 in few weeks
- ◆ **Leakage of the pools due to Earthquake?**

Consequences

- ◆ Core melt „on fresh air “
- ◆ Nearly no retention of fission products
- ◆ Large release

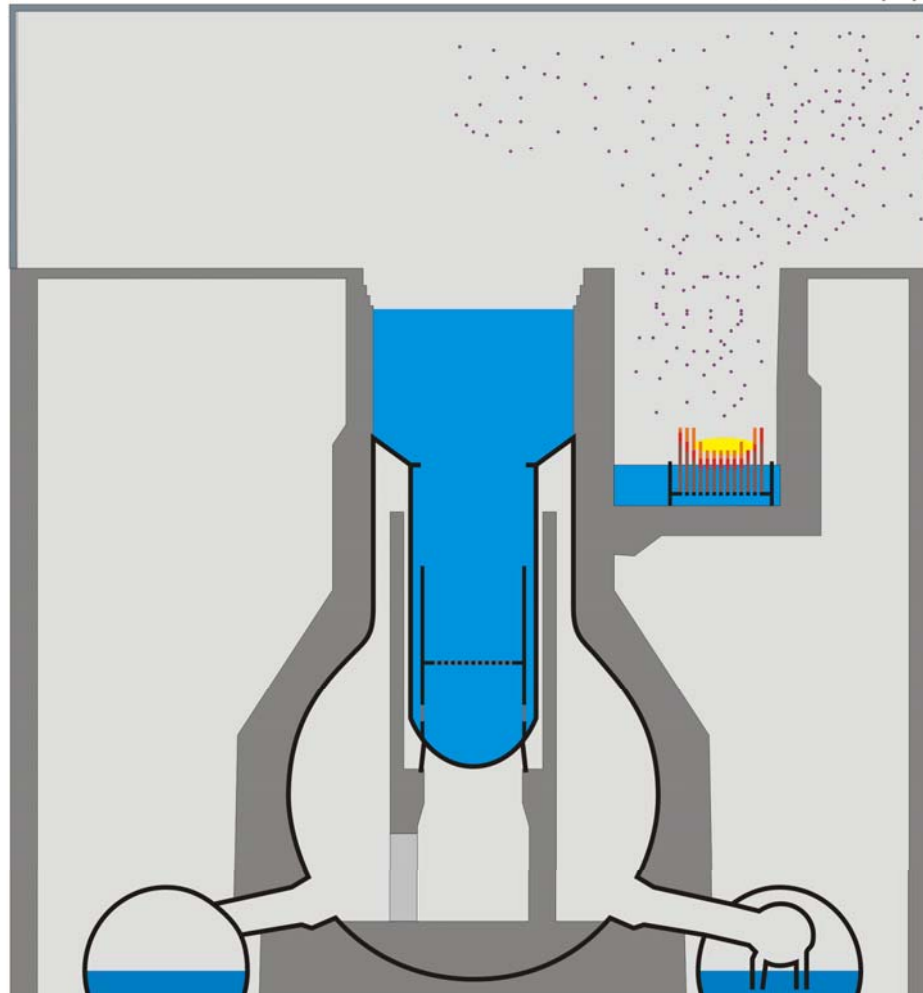

The Fukushima Daiichi Incident

5. Sources of Information



Good sources of Information

- ◆ Gesellschaft für Reaktorsicherheit [GRS.de]
 - Up to date
 - Radiological measurements published
 - German translation of japanese/englisch web pages

- ◆ Japan Atomic Industrial Forum [jaif.or.jp/english/]
 - Current Status of the plants
 - Measurement values of the reactors (pressure liquid level)

- ◆ Tokyo Electric Power Company [Tepco.co.jp]
 - Status of the recovery work
 - Casualties

Way too few information are released by TEPCO, the operator of the plant